



Single Antenna Bidirectional Radio Communications

Michael Knox
Industry Professor
Polytechnic Institute of NYU

October 25, 2011

Texas Wireless Summit 2011

Outline

- Review Full Duplex Communications
- Limitations when using Common RF Carrier
- Tx-to-Rx Cancellation Techniques
- New Single Antenna Cancellation System

Traditional Full Duplex Communications

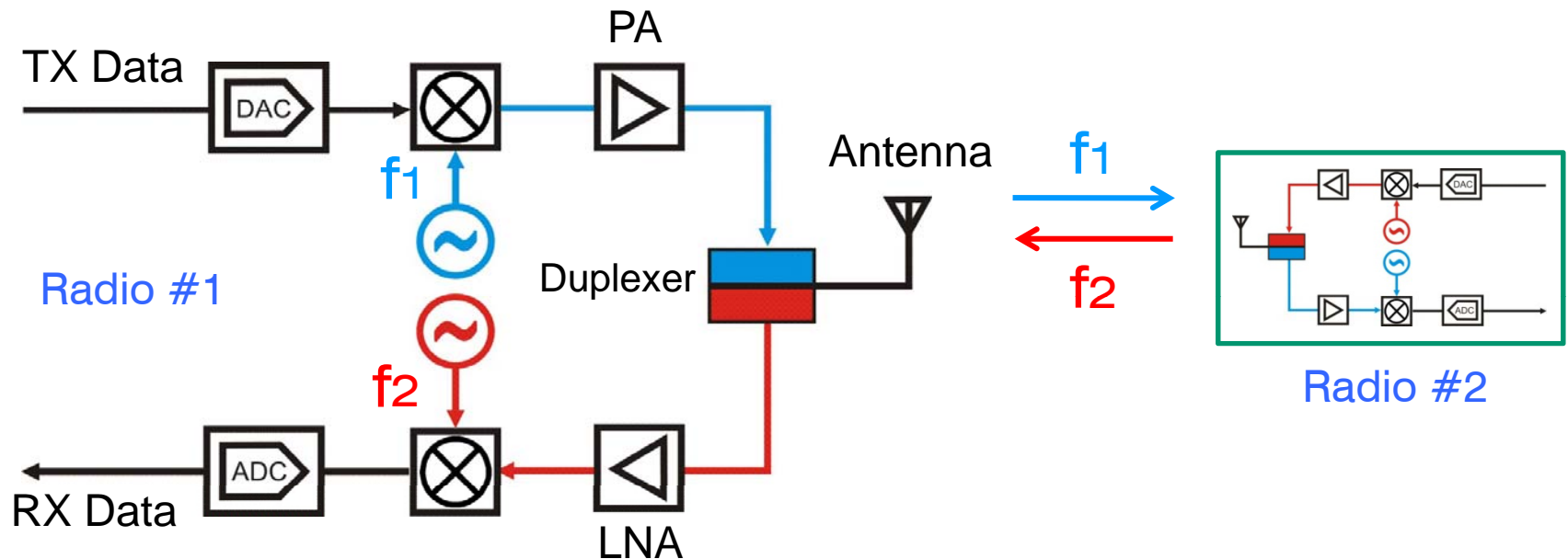

Duplexer provides frequency selective Tx-Rx isolation

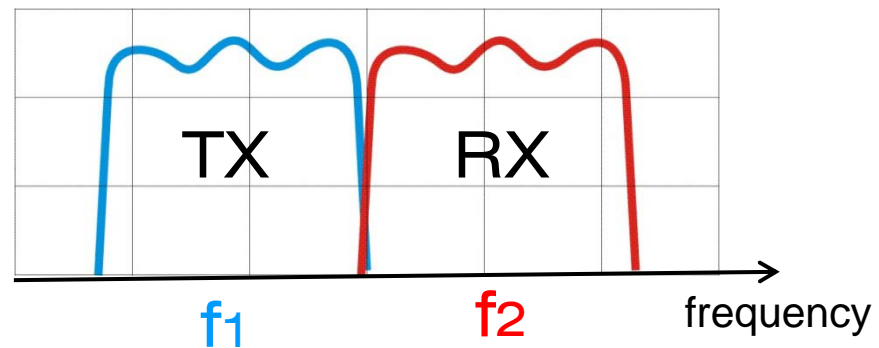

Full Duplex using Common Carrier

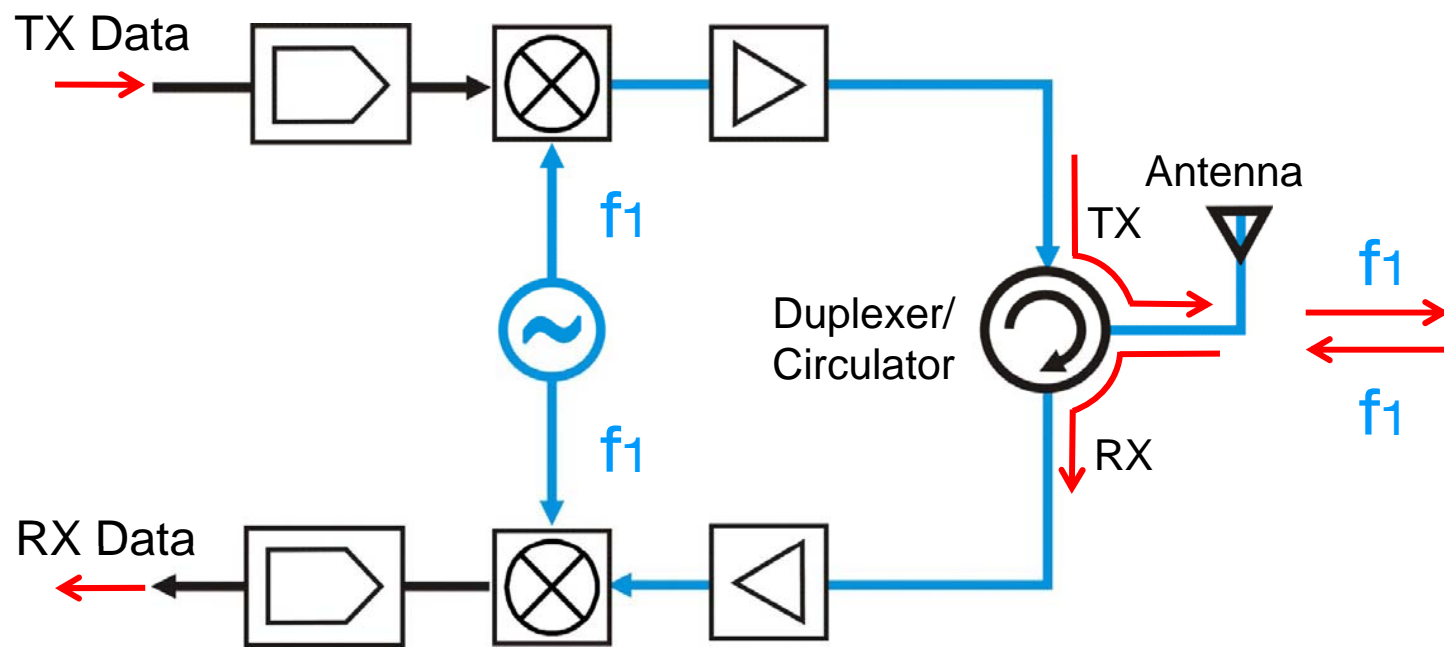

- *Theoretically achieve 2x system capacity*
- *Eliminate hidden terminal problem*
- *Low latency and fairness*
- *More efficient MAC designs*

Self-Interference Limits Performance

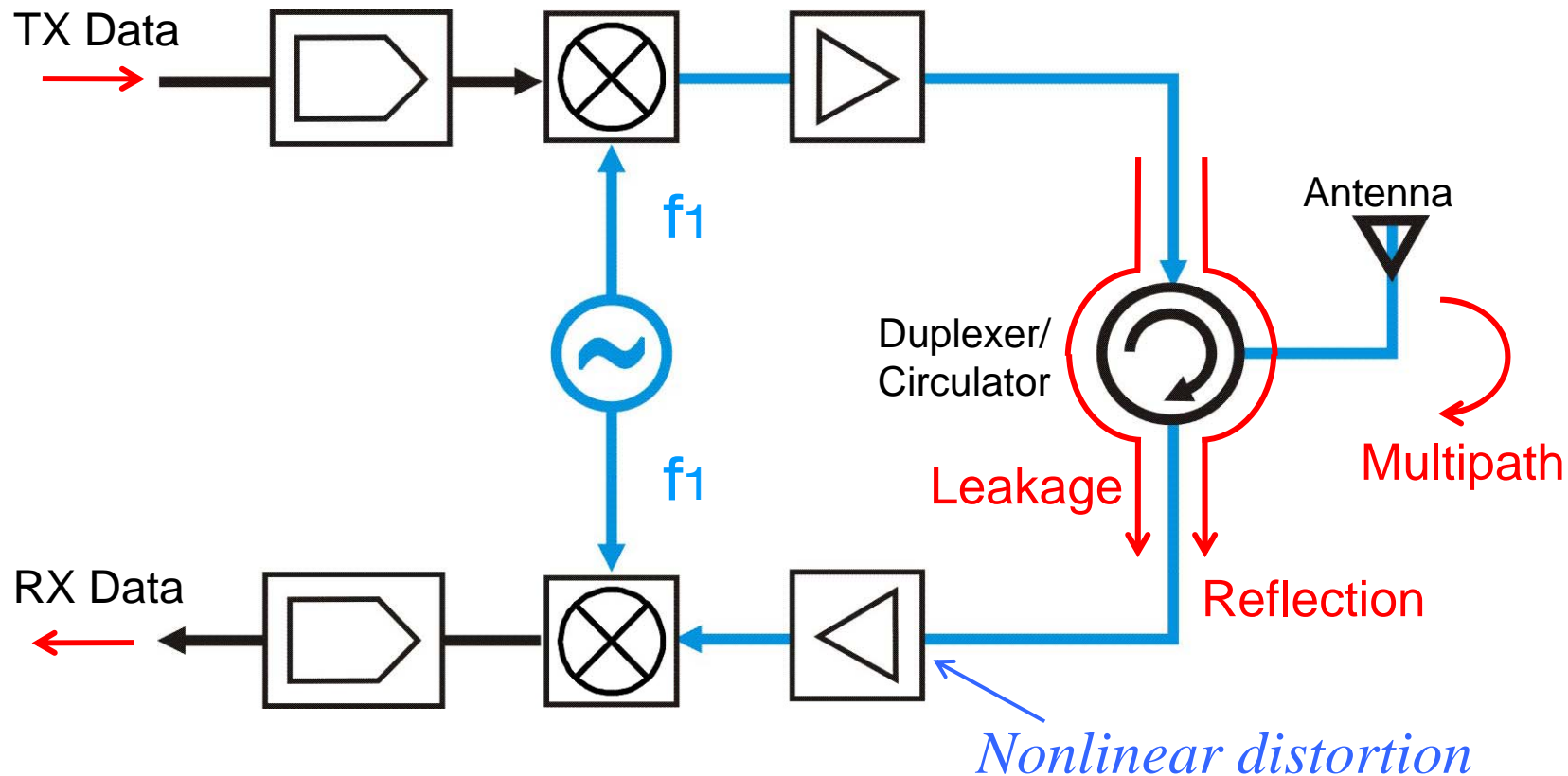

Duplexer Leakage, Antenna Reflection and Multipath Reflection severely reduces receiver dynamic range

Signals at LNA Receiver Input

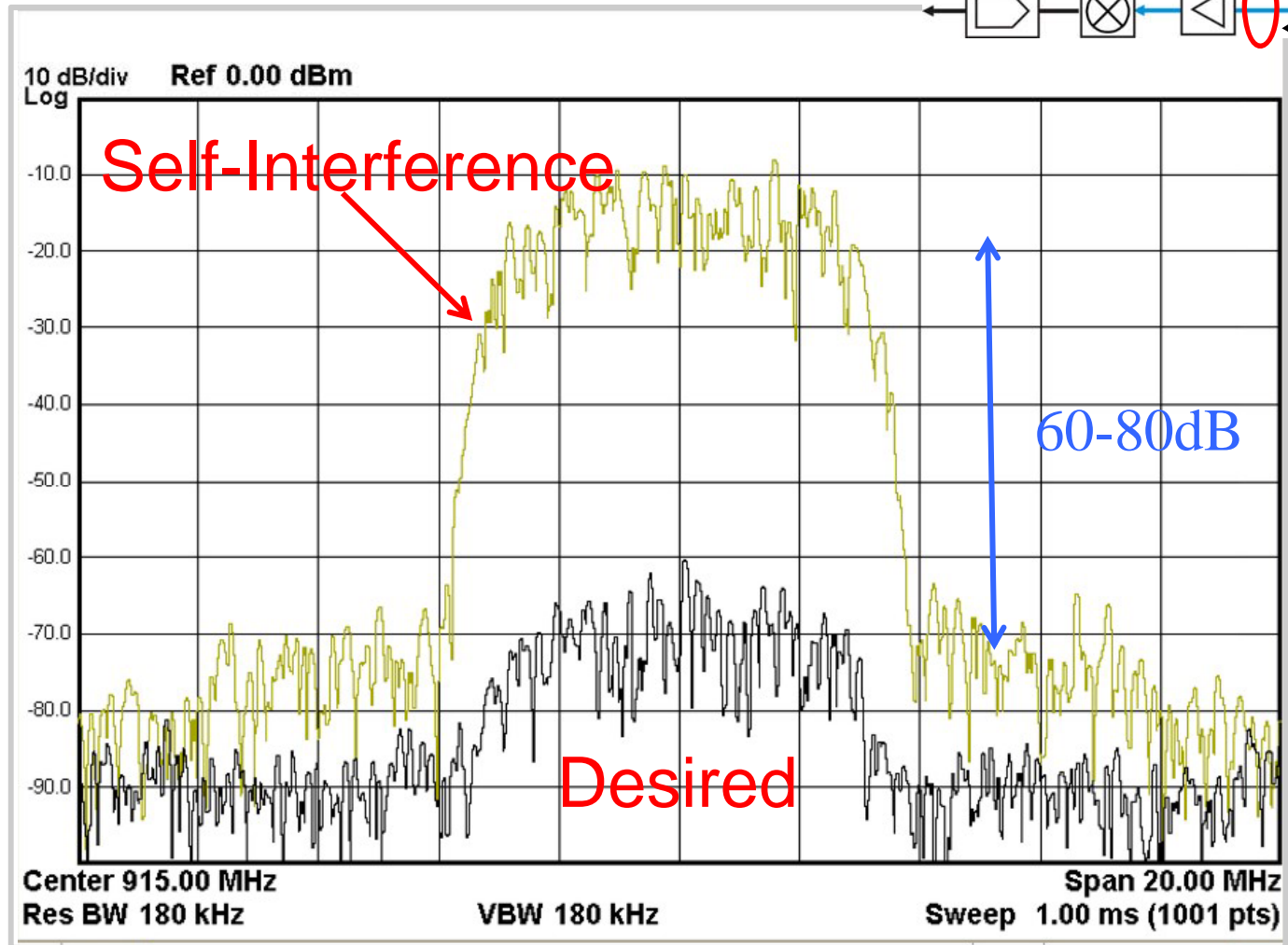
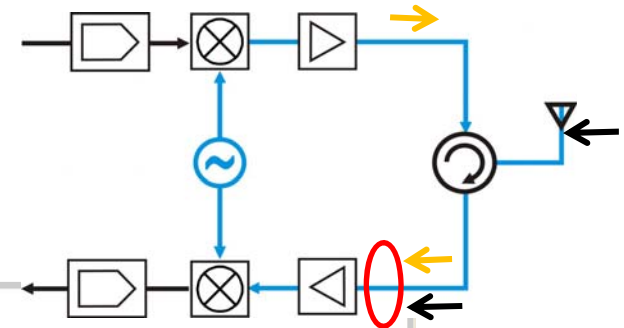

TX-RX Cancellation Techniques

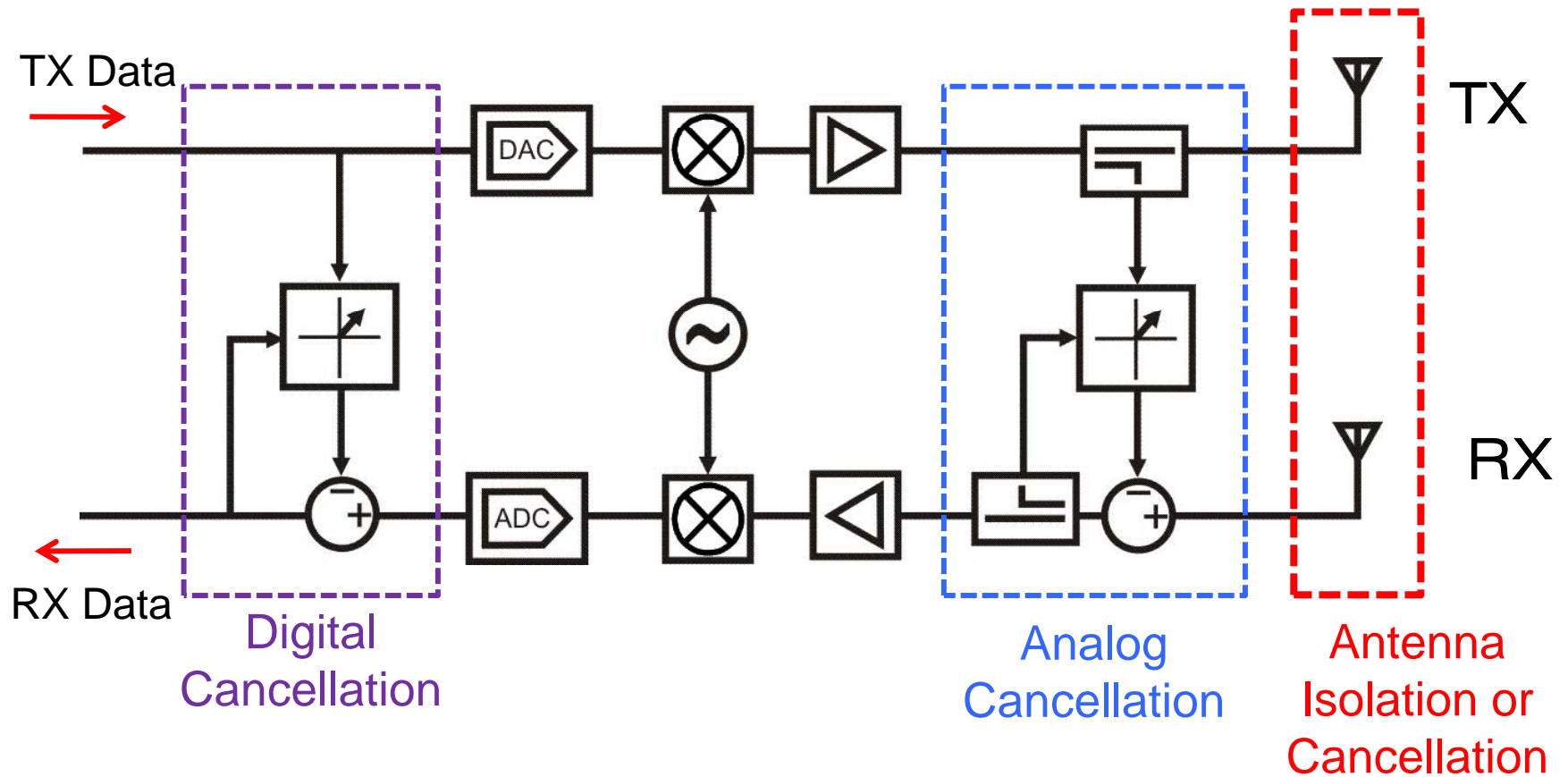

(10-20dB*)

* Reported in the literature

(25-30dB*)

(25-40dB*)

Other Published Literature

1) Microsoft Research

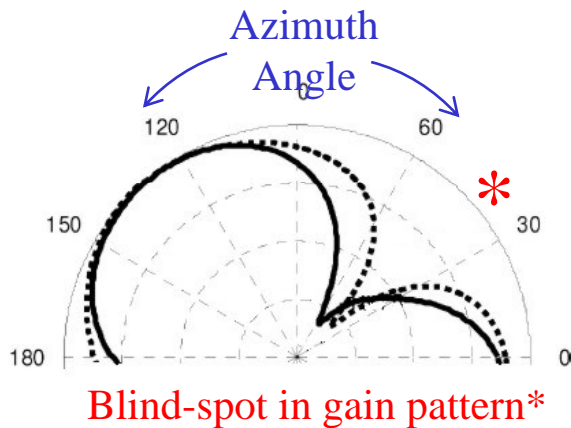
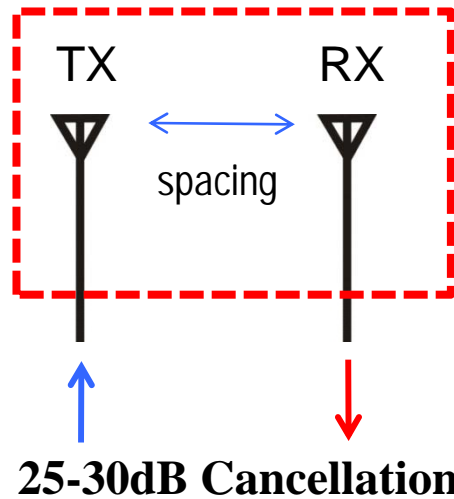

2) Stanford

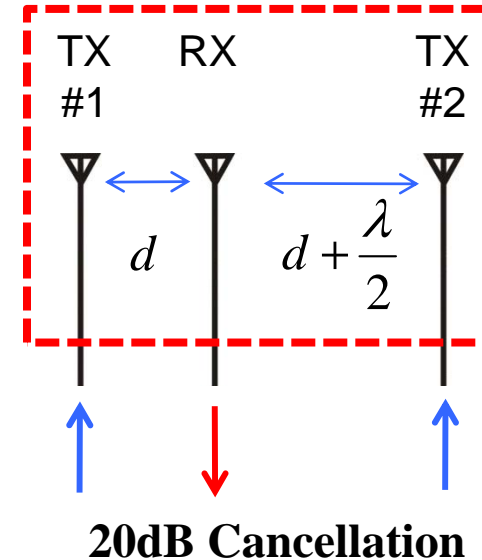

Require 2-3 "Half Duplex" antennas

- 1) Rethinking Indoor Wireless Mesh Design: Low Power, Low Frequency, Full-duplex, Bozidar Radunovic, et.al., Microsoft Research Cambridge
- 2) Achieving Single Channel, Full Duplex Wireless Communication Jung Il Cho, et.al., Stanford University

October 25, 2011

Texas Wireless Summit 2011

New “Single Antenna” Cancellation System

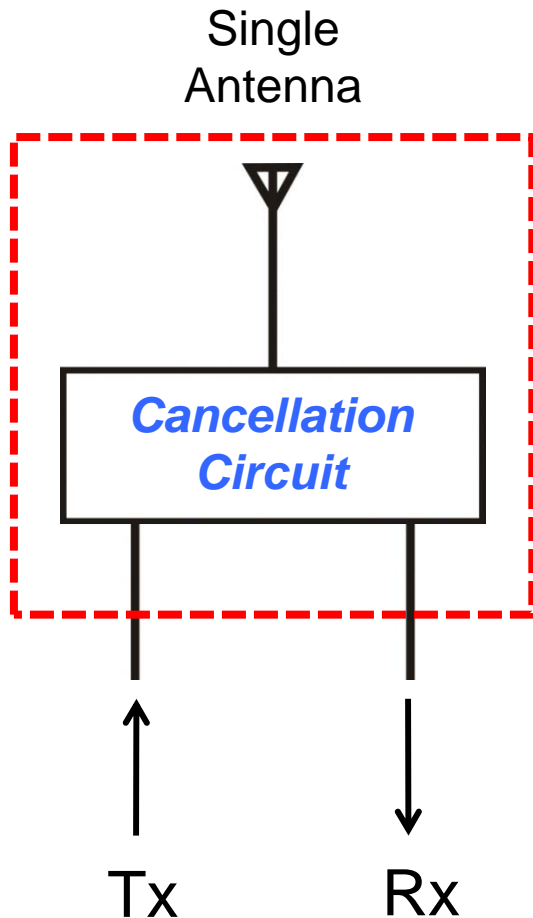

Performance Comparison

	Other	This Design
# of Antennas	2-3	1
Tx-Rx Isolation	20-30dB	40dB
Tx-Antenna Loss	3-6dB	<1dB
Antenna-Rx Loss	3-6dB	<1dB
Antenna Pattern	Nulls	Uniform
Tuning	Yes	No

New "Single Antenna" System Integration

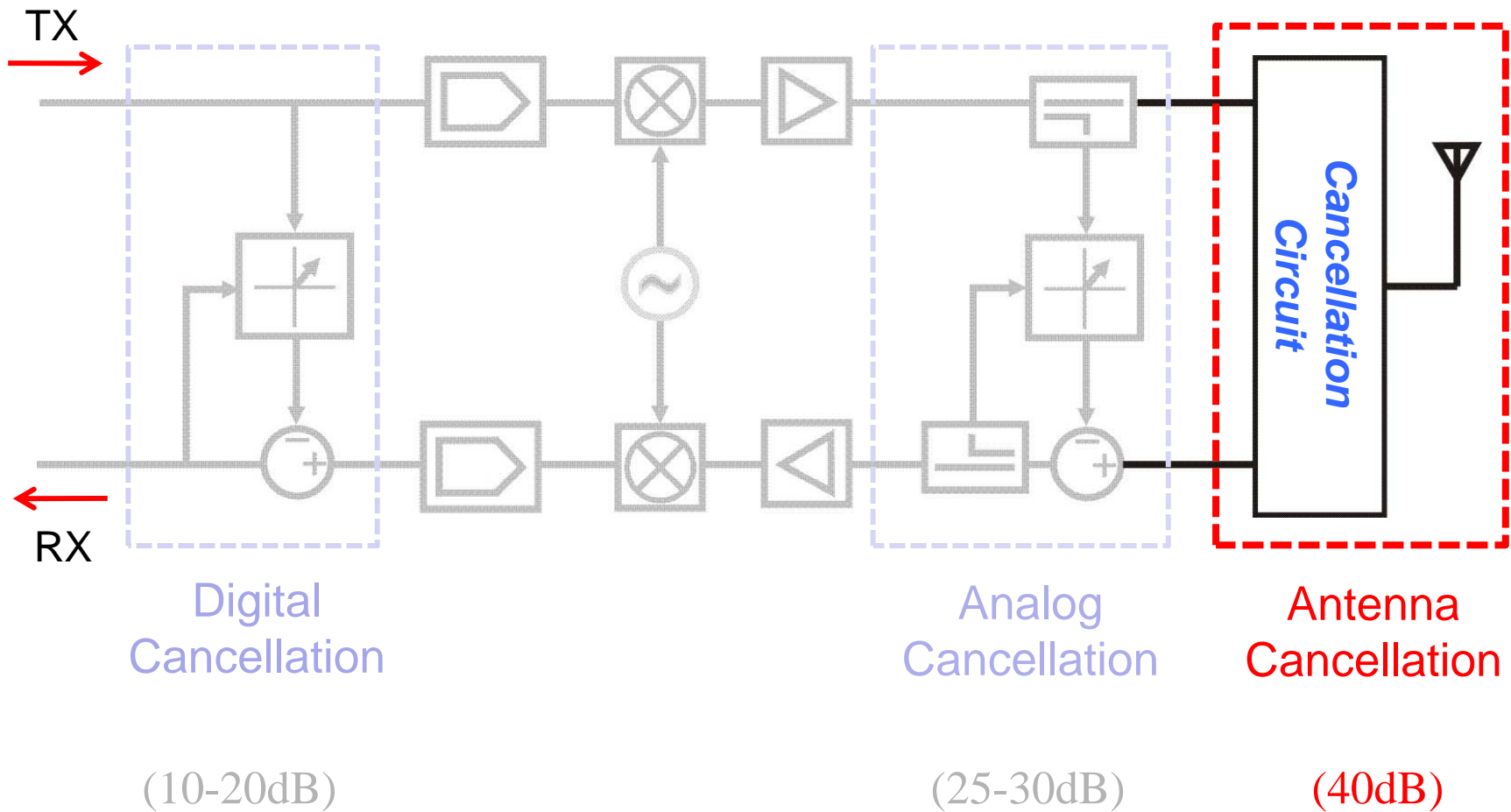

October 25, 2011

Texas Wireless Summit 2011

Single Antenna Prototype

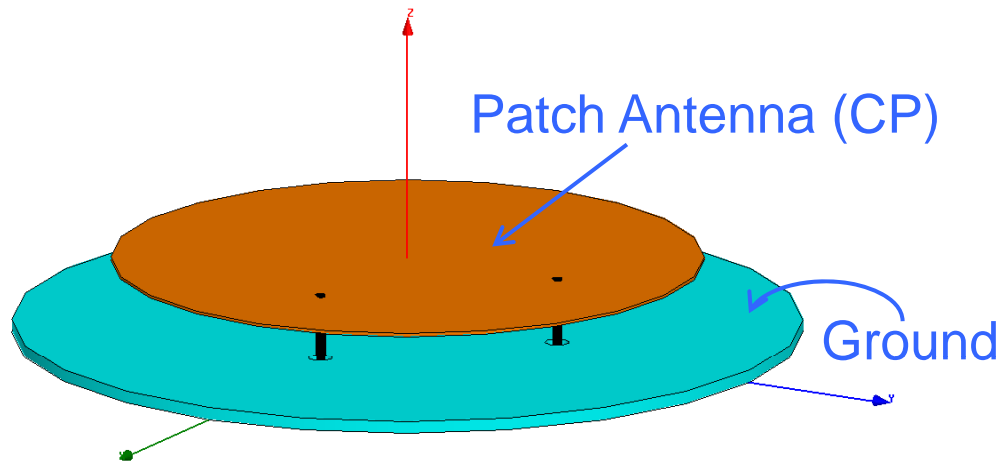

Photo of complete antenna



Assembly Diagram

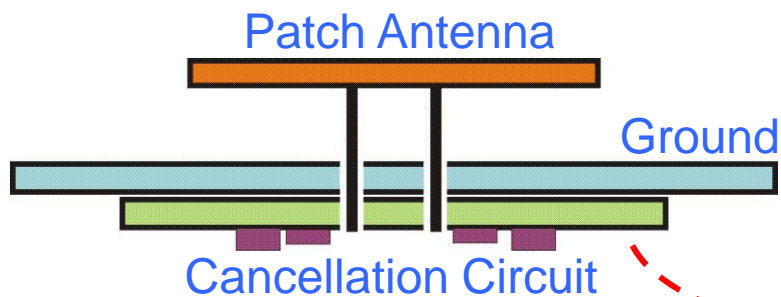
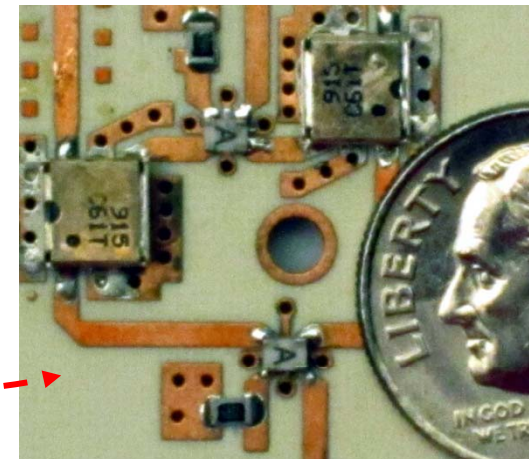
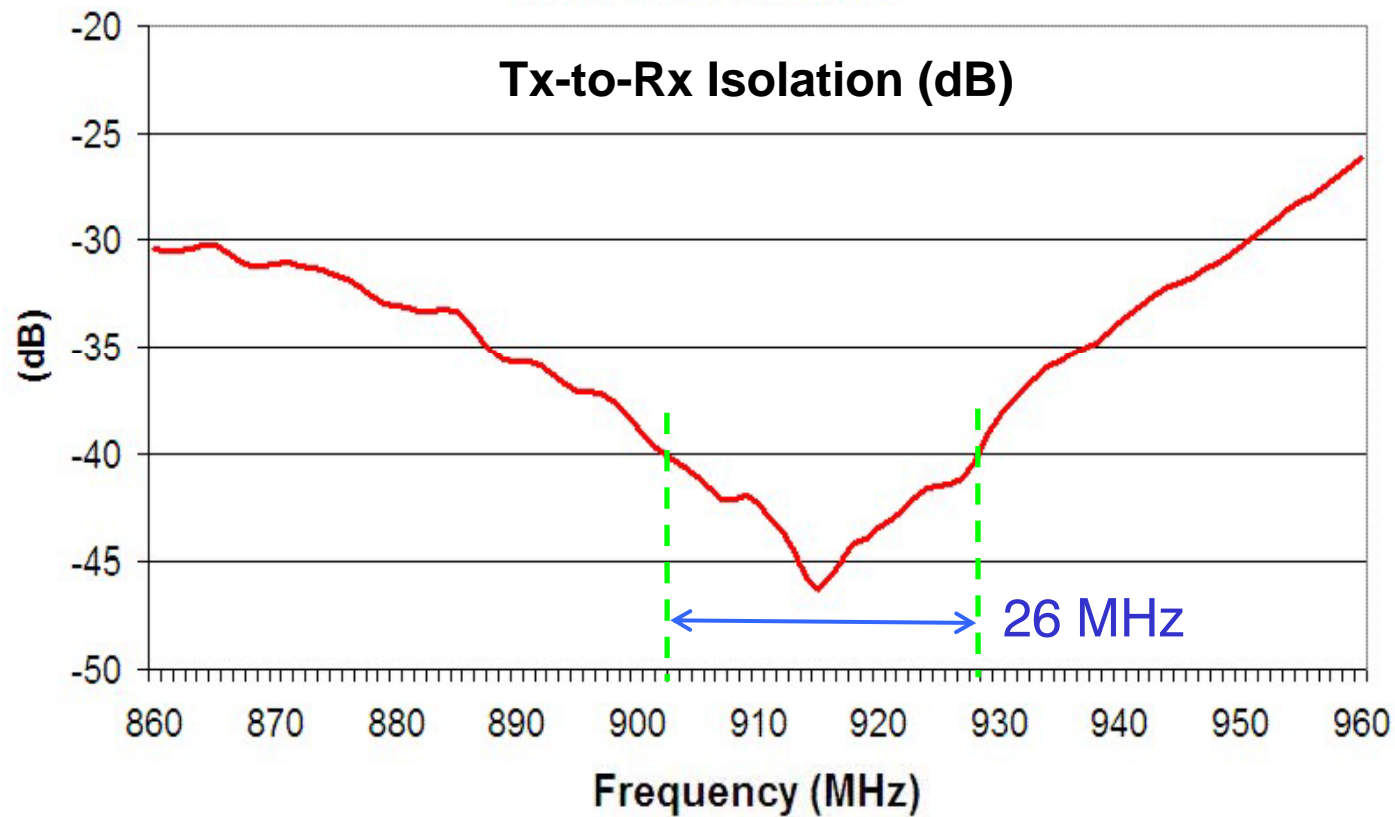
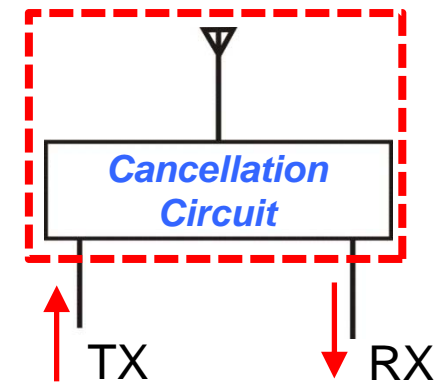

Photo of Cancellation Circuit



Patent pending

Prototype Measured Isolation



Single Antenna + Analog Cancellation

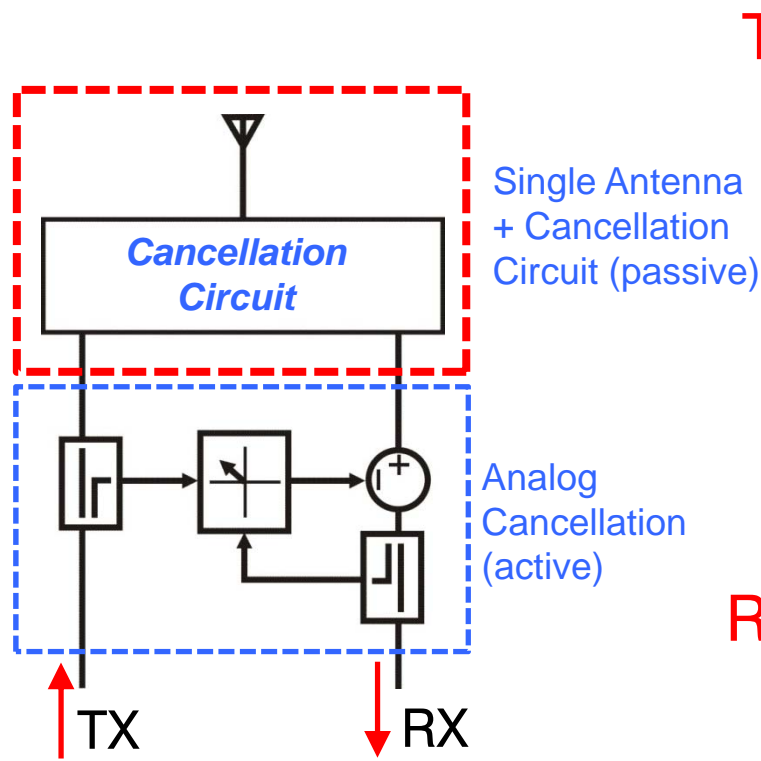

QPSK, 915MHz
Symbol Rate = 5 MHz

TX

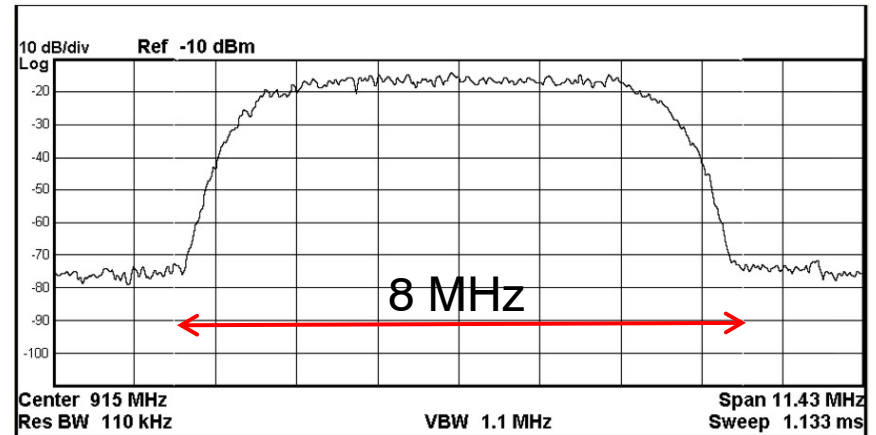

Channel Power

-0.21 dBm/ 8 MHz

Power Spectral Density

-69.24 dBm/Hz

RX

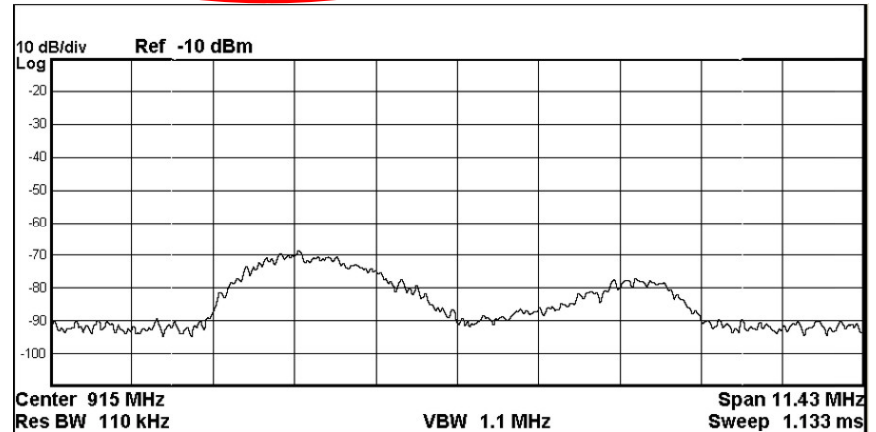

Channel Power

-58.74 dBm/ 8 MHz

Power Spectral Density

-127.77 dBm/Hz

October 25, 2011

Full Duplex System Testing

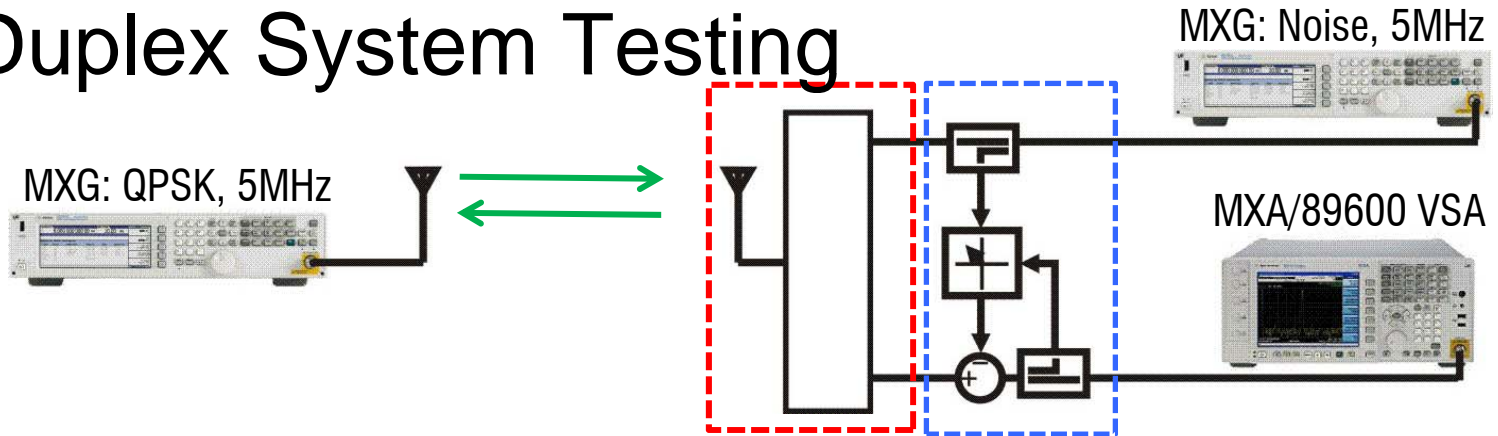

Half Duplex

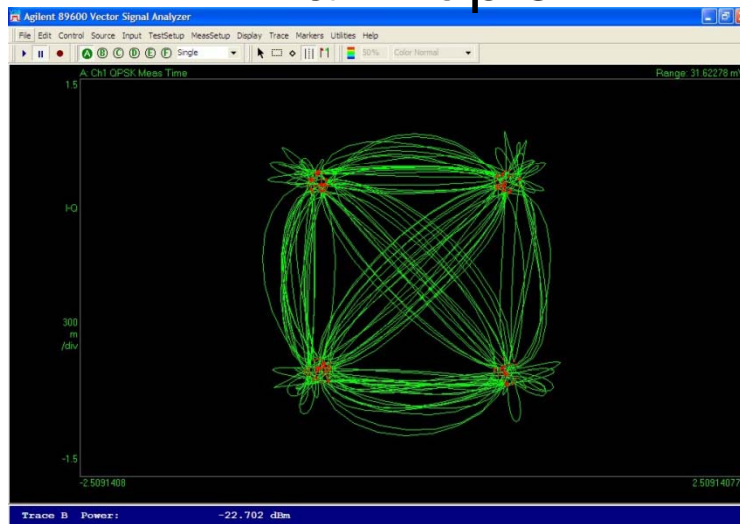

EVM = 6.9%
SNR = 23.2dB

Full Duplex

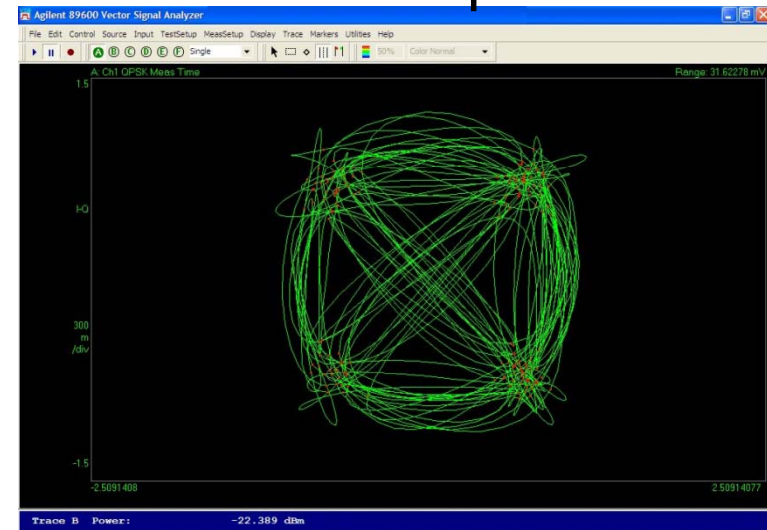

EVM = 14.6%
SNR = 16.7dB

Conclusion

- Achieved full duplex “single” antenna operation
- Self-interference cancellation of 40dB at antenna
- Low loss (<1dB) between Tx-antenna & antenna-Rx

Next Steps

- Implement SDR system with digital cancellation
- Examine MAC architectures that exploit full duplex
- Full duplex MIMO